

JDP

BUILT FOR LIFE

**PARTS LIST
&
MOUNTING
INSTRUCTIONS**

405

Ransomes ROPS

405 RANSOMES ROPS PARTS LIST

BRACKETS, SHIELDS, ETC.:

Item	Qty	Description
1		L&R Front brackets

HARDWARE:

Qty	Description
4	8x30x1.25mm Hex bolts (gr.5)
4	8x1.25mm Whiz nuts (gr.5)
2	10x35x1.5mm Hex bolts (gr.5)
2	10x1.5mm Whiz nuts (gr.5)
12	12x50x1.75mm Hex bolts (gr.5)
12	12x1.75mm Whiz nuts (gr.5)
2	7/16"x3" Hex bolts (gr.8)
2	7/16" Hex nuts (gr.5)
2	1/2" Flatwashers

MISCELLANEOUS:

Item	Qty	Description
**	2	3"x3" rubber mounts (as per pattern)
**	2	3"x5" rubber mounts (as per pattern)
2	1	Seat belt kit

405 RANSOMES ROPS MOUNTING INSTRUCTIONS

1. Remove the headlights, hydrostatic pedal stop, and upper steps. Tilt the seat plate open.
2. Remove the hardware used to fasten the fuel tank to the chassis. Move the fuel tank slightly to the rear and outside.
3. Locate the three 12x30mm factory hex bolts used to fasten the lower portion of the front platform to the left and right frame rails and remove.
4. Drill a 7/16"dia. hole through the left side of the front platform as shown in figure 1.

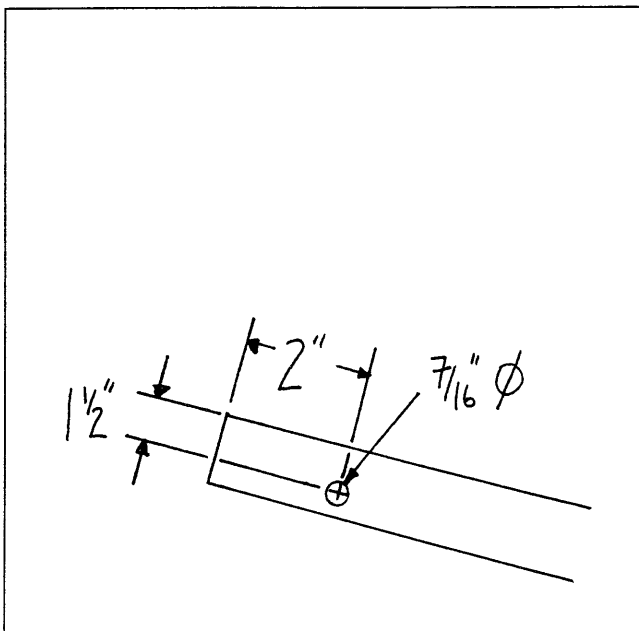

Figure 1

5. Take the left front bracket (1) and position it underneath the front platform, against the three-hole bolt pattern in step 3, with the ROPS mounting plate towards the front and inside. Loosely bolt the bracket to the

chassis using the 12x50x1.75mm hex bolts and hex nuts provided. NOTE: Keep the bolt heads toward the outside and use one factory flatwasher between the bracket and platform on the bottom hole. (see figure 2)

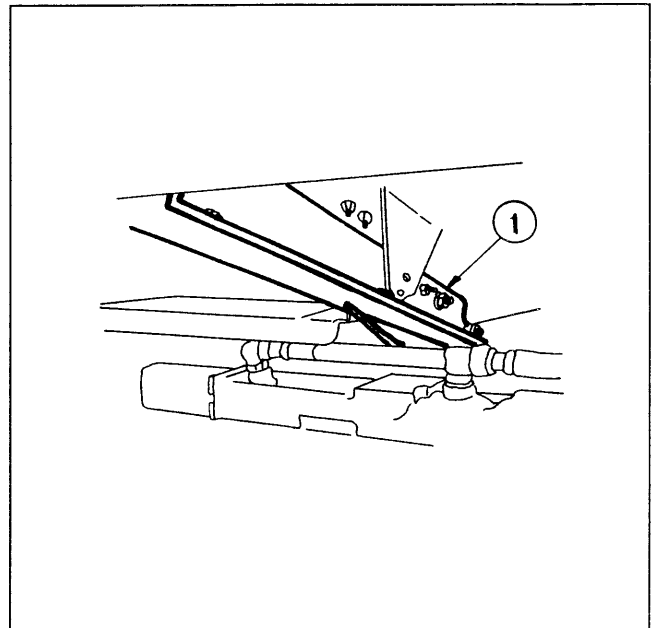

Figure 2

6. Loosely bolt the bracket front to the platform using the 10x35x1.5mm hex bolt and hex nuts supplied. (see figure 2)
7. Take the left upper step removed in step 1, and reattach it to the chassis using the factory bolts at the bottom and 8x30x1.25mm hex bolts and hex nuts supplied at the top.
8. Repeat step 5-7 for the right front bracket. NOTE: Bolt the hydrostatic pedal stop to the outside of the platform when you repeat step 6. The top pedal adjustment bolt may have to be shortened.

NOTE:

All references to left and right are taken from the operator's point of view when he/she is sitting in the seat.

405 RANSOMES ROPS MOUNTING INSTRUCTIONS

(see figure 3)

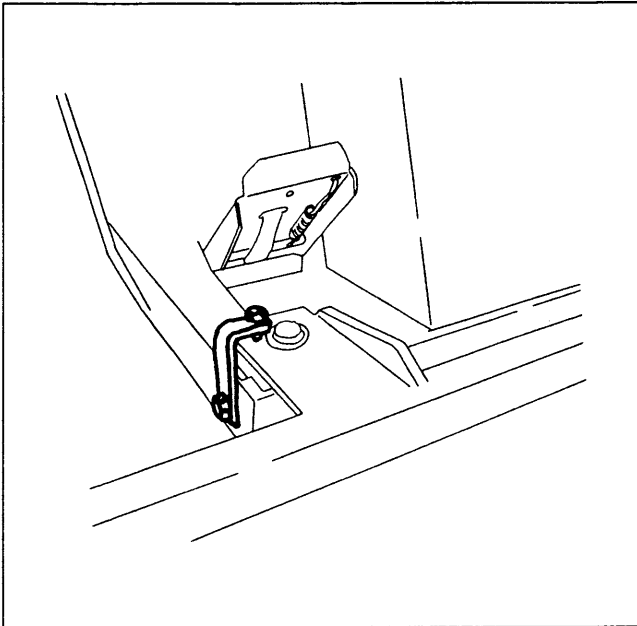

Figure 3

9. Tighten all front bracket bolts. Reattach the fuel tank moved in step 2.

10. Using the top, front hole in the left, front bracket as a guide drill a 9/16" dia. hole through the top of the platform. Repeat for the right side. (see figure 4)

11. Locate the two factory bolts used to fasten the outside reel mowers to the stabilizer bracket located behind the seat and remove.

12. **NOW YOU ARE READY TO MOUNT THE ROPS.** Place one 3"x3" rubber mount over each 9/16" dia. hole in the top of the front platform. Then place one 3"x5" rubber mount over each two-hole bolt pattern from step 11, with the holes toward the

inside. Lift the ROPS, using the lift bolts located near the roof, directly above the unit.

Slowly, lower the ROPS until the ROPS mounts rest solidly on the rubber mounts. Bolt the ROPS snugly to the front brackets and factory stabilizer bracket using the 12x50x1.75mm hex bolts and hex nuts supplied.

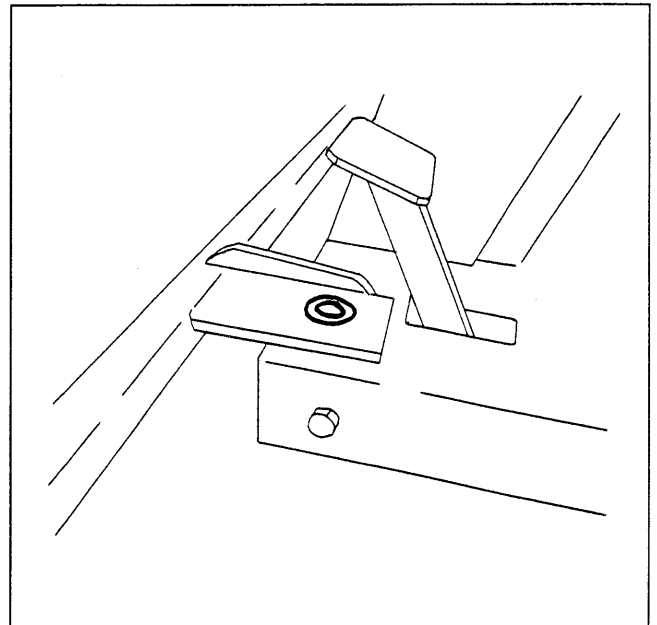

Figure 4

13. Locate the 15/32" dia. hole in the left, rear, inside frame member of the ROPS. Take one of the seat belt (2) anchors and position it against the inside of the tube. Bolt the anchor to the frame using the 7/16"x3" hex bolt, hex nut, and lockwasher provided. (see figure 5)

14. Repeat step 13 for the right side.

15. If the ROPS is equipped with the golf ball protection kit,

NOTE:

All references to left and right are taken from the operator's point of view when he/she is sitting in the seat.

405 RANSOMES ROPS MOUNTING INSTRUCTIONS

remove the side shipping brackets.

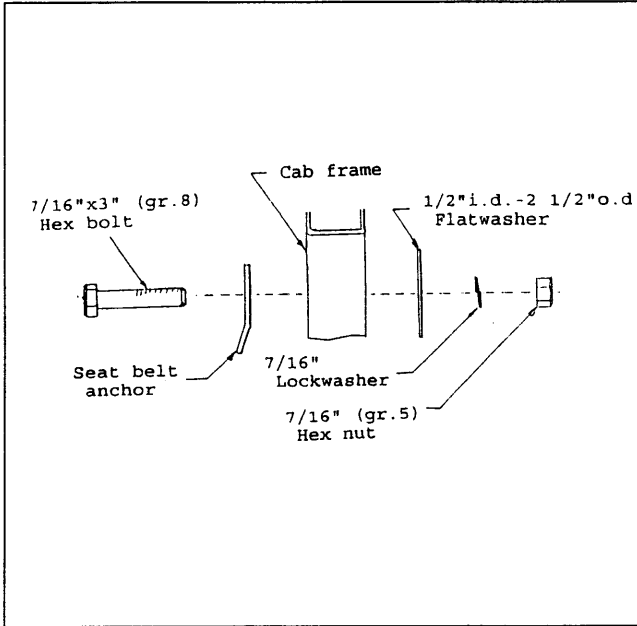

Figure 5

NOTE:

All references to left and right are taken from the operator's point of view when he/she is sitting in the seat.