

JODALE-PERRY

MOUNTING INSTRUCTIONS

MODEL: MK.VII 755 JOHN DEERE WITH 70/JD LOADER
CODE: JD-65

INCLUDES:
MOUNTING INSTRUCTIONS
PARTS LIST

JDP
BUILT FOR LIFE

JD-65-02

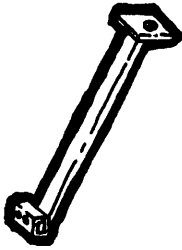

- JD-65-02 REAR MOUNTS (L&R)
- JD-65-05 LEFT UNDERHOOD SHIELD
- JD-65-06 RIGHT UNDERHOOD SHIELD
- JD-65-07 HOOD SHIELD
- JD-65-08 BRAKE SHIELD
- JD-65-09 HYDROSTATIC SHIELD
- JD-65-10 STABALIZER BRACKETS (L&R)

JD-65-05

JD-65-06

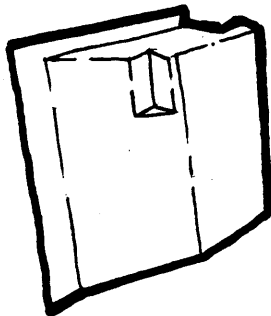
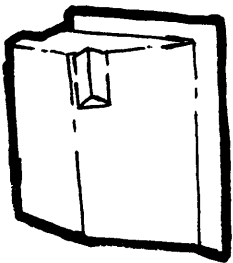

BOLT LIST:

- 4 ~~5/16~~^{3/8} "x1 1/2" BOLT, NUT, WASHER
- 2 1/2"x3" BOLTS, NUTS, WASHERS
- 2 2 1/2" FLAT WASHERS
- 2 RUBBER MOUNTS
- 30 1/4"x20x3/4" DRILL & TAP SCREWS
- 8 1/4"x3/4" BOLTS, NUTS, WASHERS
- 4 1/2"x#8 METAL SCREWS
- 2 ~~5/16" LOCK WASHERS~~
- 2 ~~1/2"x40x20 BOLT~~

JD-65-07

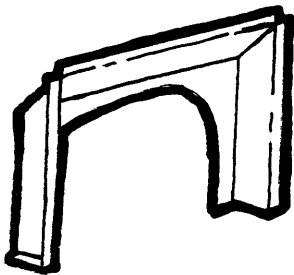

- 2 12 1/2"x21" FLOORMAT
- 60" HOOD RUBBER
- 60" PINCH WELT
- 1 36"x26"x1/2" VINYL

JD-65-08

JD-65-09



JD-65-10

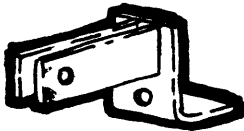

NOTE: (SEE DRAWING #5) WITH A 70 JOHN DEERE LOADER, THE TABS (11) MUST BE CUT OFF.

THE FRONT WINDOWS MUST BE REMOVED AND REPLACED WITH METAL DOORS FROM THE INSIDE TO ALLOW THE OPERATION OF THE LOADER DETACHING LEVERS.

1. REMOVE HEAD LIGHTS, 4 WAY FLASHERS, AND HANDLES FROM THE FENDERS.
2. REMOVE SHIELDS IN FRONT OF THE SEAT IN ORDER TO GET AT THE SEAT BOLTS.
3. REMOVE THE SEAT, INCLUDING THE TRACK.
4. (SEE DRAWING #1) CUT HOOD 4" FROM THE REAR. INSTALL PINCH WELT (0) ON THE CUT EDGES. SCREW REAR PORTION OF THE HOOD TO THE DASH WITH 4-#8 SCREWS (1).
5. (SEE DRAWING #2) BOLT LEFT AND RIGHT REAR BRACKETS (2) TO THE AXLE HOUSING WHERE THE ROLL BAR WAS BOLTED BEFORE. DO NOT TIGHTEN BOLTS.
6. (SEE DRAWING #3) PLACE RUBBER MOUNTS (3) ONTO BOTH REAR MOUNTING BRACKETS AND MOUNT CAB. PULL CAB BACK AGAINST THE FENDERS AND TIGHTEN BOLTS ON THE REAR BRACKETS.
7. (SEE DRAWING #4) BOLT FRONT MOUNTS (4) THROUGH THE FLOOR BOARDS.
8. (SEE DRAWING #5) PLACE O-RUBBER ON THE LEFT SIDE UNDERHOOD SHIELD (5) AND SCREW IT TO THE OUTSIDE OF THE CAB.
9. (SEE DRAWING #6) PLACE O-RUBBER ON THE RIGHT SIDE UNDERHOOD SHIELD AND SCREW TO THE OUTSIDE OF THE CAB.
10. (SEE DRAWING #4) PLACE O-RUBBER ONTO THE HOOD SHIELD (7) AND SCREW TO THE INSIDE OF THE CAB.
POSITION BRAKE SHIELD (8) AND SCREW INTO PLACE.
POSITION HYDROSTATIC SHIELD AND SCREW INTO PLACE.
11. BOLT 3PT. STABILIZERS BRACKETS (10) TO THE AXLE WHERE THE ROLL BAR USED TO BE.
ATTACH 3PT. CHAINS TO THE BRACKETS WITH THE PINS.
12. CUT THE FLOORMATS TO FIT SNUGGLY AROUND ALL OPENINGS.
13. CONNECT THE ELECTRICAL EQUIPMENT TO A 12 VOLT SOURCE USING THE 30 AMP. INLINE FUSE.

PLEASE NOTE: THERE IS NO WARRANTY ON GLASS.
WE ARE NOT RESPONSIBLE FOR INJURY TO ANYONE
BY OUR PRODUCTS OR ANY PART THEREOF.

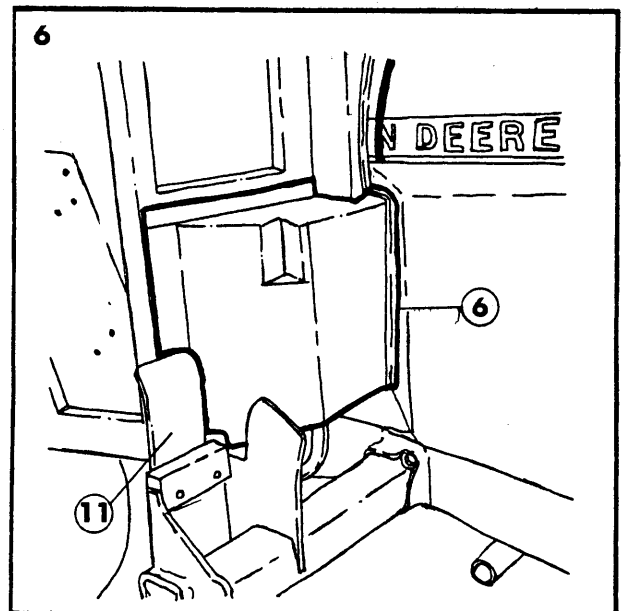
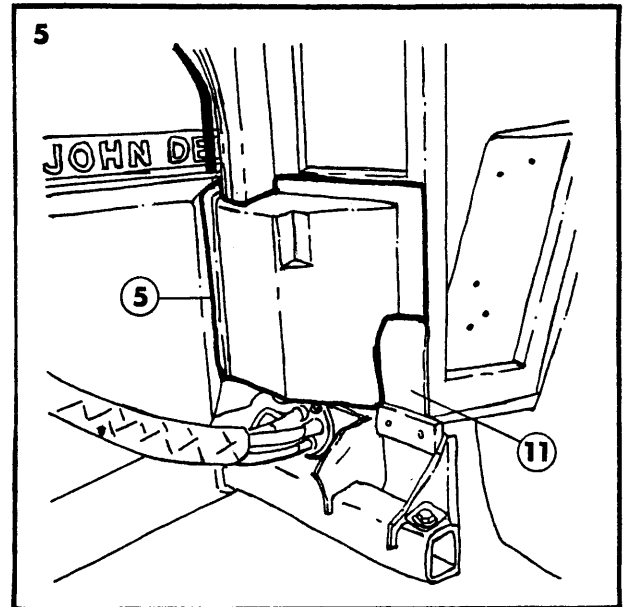
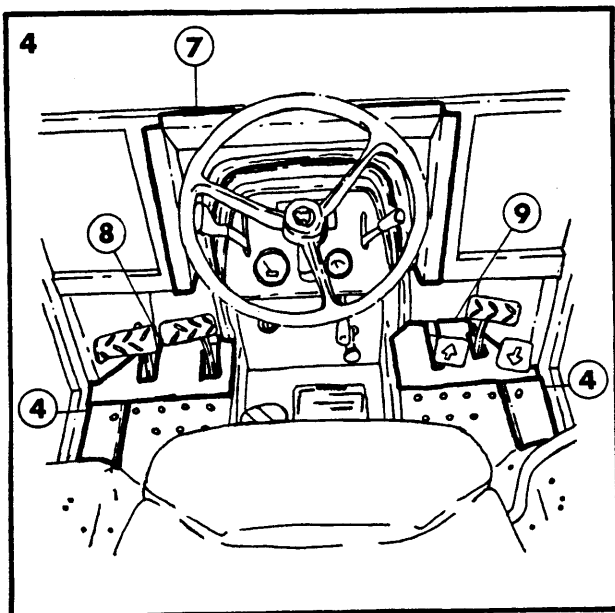
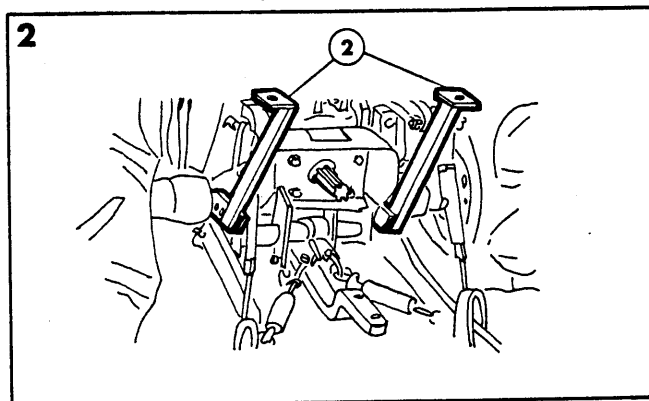
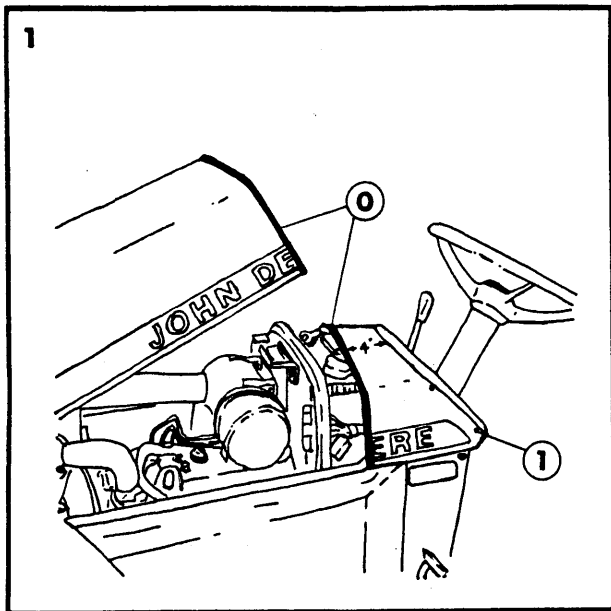

3

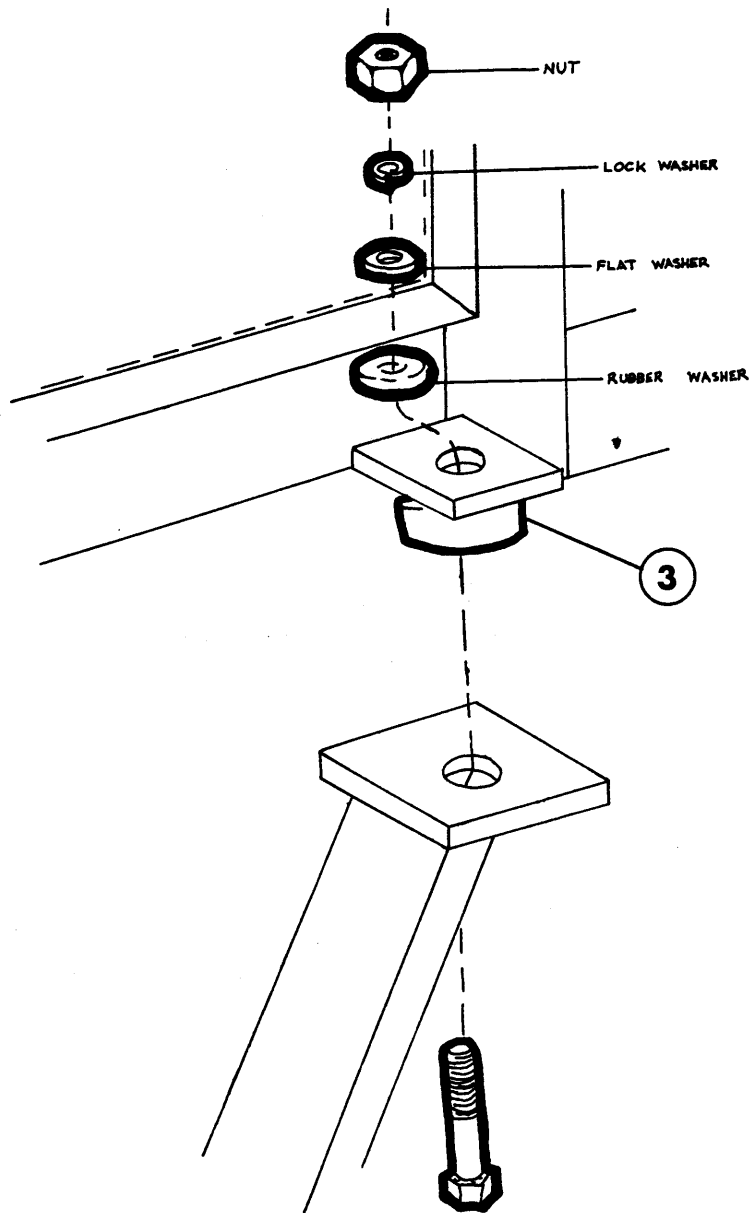

PARTS LIST:

- 2 3/8" MPTx3/8" BARB NYLON FITTING
~~1 3/8" MPTx3/8" BARB NYLON FITTING~~
 4 MH-6 HOSE CLAMPS
 25' 3/8" BRAIDED HOSE

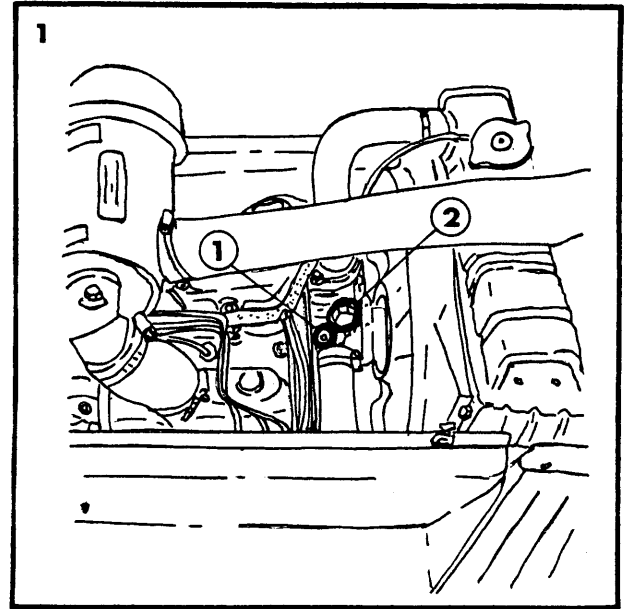

1. DRAIN ANTI-FREEZE.
2. REMOVE PLUG (1&2).
3. INSTALL 3/8" MPTx3/8" BARB FITTING INTO (1) SUCTION.
4. INSTALL ~~ONE~~ 3/8" BARB FITTING INTO (2) PRESSURE.
5. CONNECT 3/8" BRAIDED HOSE TO (1&2) AND ROUTE UP THE LEFT FRONT CAB POST.
6. CONNECT HOSE (1) TO THE WATER VALVE.
7. CONNECT HOSE (2) TO THE HEATER CORE.
8. FILL IN ANTI-FREEZE.