

JDP

BUILT FOR LIFE

Parts List
&
Mounting
Instructions

*951D ROPS
Ransomes*

*951D Ransomes ROPS
Parts List*

BRACKETS, SHIELDS, ETC.:

| Item | Qty | Description |
|------|-----|---------------------------|
| 3 | L&R | Deck latch brackets |
| 4 | 4 | Deck latch bracket spacer |
| 7 | L&R | Front brackets |
| 6 | L&R | Front bracket supports |
| 5 | L&R | Rear brackets |
| 2 | L&R | Rear deck stop |

HARDWARE:

| Qty | Description |
|-----|----------------------------------|
| 4 | 12x50x1.75 mm Hex bolts (gr.5) |
| 5 | 1/4"x3/4" Whiz bolts |
| 5 | 1/4" Hex nuts |
| 12 | 1/2"x1 1/2" Hex bolts (gr.8) |
| 8 | 1/2"x3" Hex bolts (gr.8) |
| 20 | 1/2" Hex nuts |
| 24 | 1/2" Lockwashers |
| 4 | 9/16"i.d.-2 1/2"o.d. Flatwashers |

MISCELLANEOUS:

| Item | Qty | Description |
|------|-----|--|
| | 2 | 11 1/2" gas shock cables (pre-installed) |
| ** | 4 | 9/16"i.d.-2 1/2"o.d. Rubber flatwashers |
| ** | 4 | 9/16"i.d.-3"o.d. Rubber mounts |
| 8 | 1 | Seat belt kit |

951D Ransomes ROPS Mounting Instructions

1. Lower all mower decks. Remove the side deck stops located on the front and rear fenders. Then remove the deck stop wheels from the deck stops.
2. Take the left front deck stop (1) and position it where the factory deck-stop was removed in step 1. Bolt the stop to the fender using the factory hardware. Then, attach one of the deck stop wheels, removed in step 1, to the rear side of the stop using the factory hardware (see Figure 1).

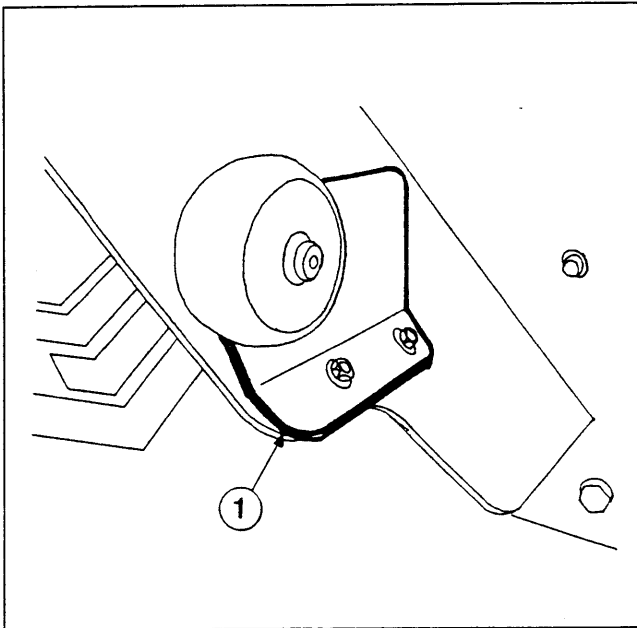

Figure 1

3. Take the left rear deck stop (2) and position it where the factory deck stop was removed in step 1. Bolt the stop to the fender using the factory hardware. Then, attach one of the deck stop wheels, removed in step 1, to the front side of the stop using the factory hardware (see Figure 2).

4. Remove the left deck latch, located beside the front of the hood, latch spring, and adjustable latch stop. Locate the tab on the factory deck mount, used to hook in the bottom of the spring, and cut it off to allow room for the cab.

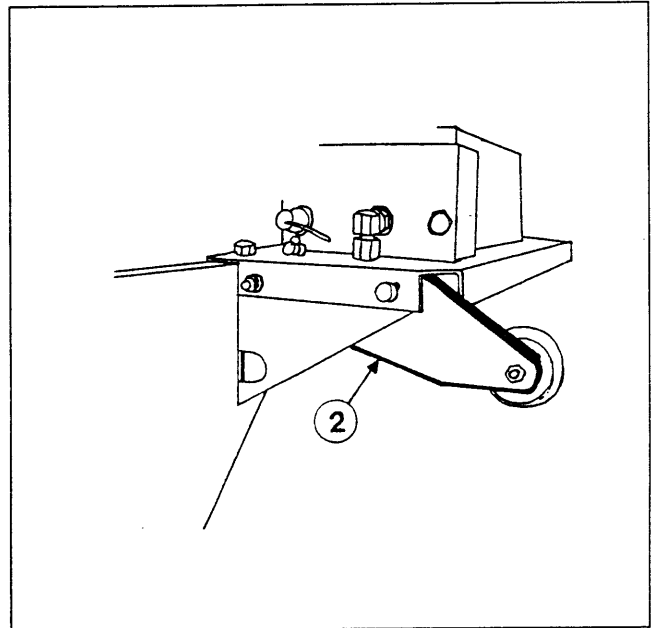

Figure 2

5. Take the left deck latch bracket (3) and position it against the outside of the factory deck mount with the bracket tab holes in-line with the deck mount latch holes from step 2. Ensure the latch 1/2"x1 1/2" hex bolts, hex nuts, and spring tab is towards the front. Loosely bolt the bracket to the mount using the lockwashers supplied. Locate the two-hole bolt pattern at the bottom of the bracket and position one deck latch bracket spacer (4) between each hole and deck mount. Bolt the bracket, through the spacer and mount, to the chassis using the

NOTE:

All references to left and right are taken from the operator's point of view when he/she is sitting in the seat.

951D Ransomes ROPS Mounting Instructions

1/2"x3" hex bolts, hex nuts, and lockwashers provided. Tighten all bracket bolts (see Figure 3).

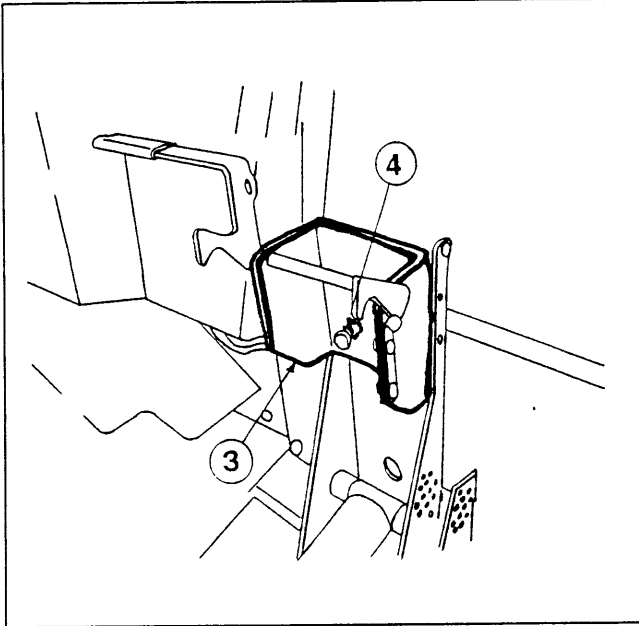

Figure 3

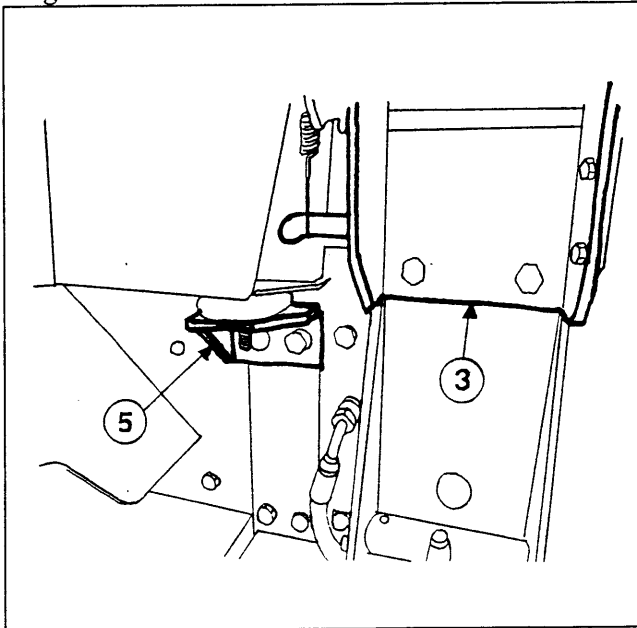

Figure 4

6. Attach the left deck latch, latch spring, and latch stop to the deck latch bracket (3) in the same manner

as removed in step 4 using the factory hardware (see Figure 4).

7. Repeat steps 2-6 for the right side.

8. Locate the top two 12mm hex bolts, behind the left fender, used to fasten the front deck mount to the chassis and remove. Take the left rear bracket (5) and position it against the two-hole bolt pattern with the cab mounting plate to the front and outside. Loosely bolt the bracket, through the mount, to the chassis using the 12x50x1.75mm hex bolts and 1/2" lockwashers supplied (see Figure 4).

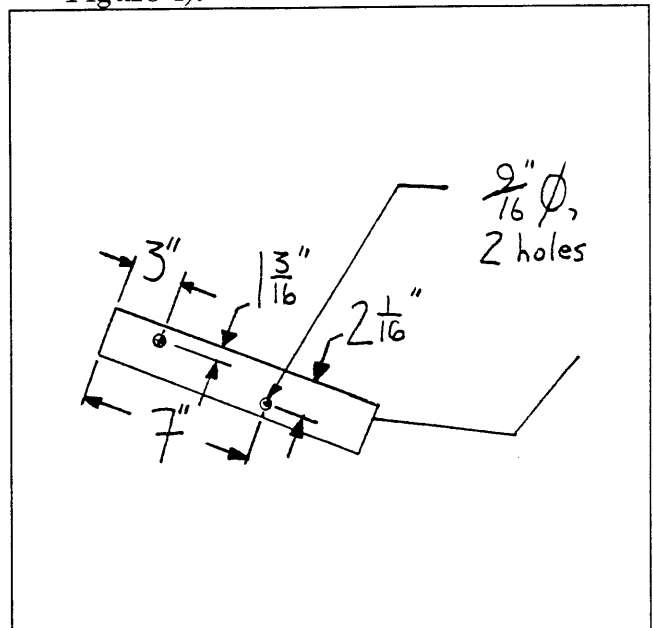

Figure 5

9. Repeat step 8 for the right rear bracket.

10. Move to the operator foot platform. Locate the two 8mm hex bolts to the left of the brake pedal and remove. Using the holes as guides drill two

NOTE:

All references to left and right are taken from the operator's point of view when he/she is sitting in the seat.

951D Ransomes ROPS Mounting Instructions

9/16" dia. holes through the platform and pedal bracket.

11. Drill two 9/16" dia. holes through the left side of the operator foot platform as shown in Figure 5.
12. Repeat step 11 for the right side.
13. Drill two 9/16" dia. through the top of the operator foot platform on the right side as shown in Figure 6.

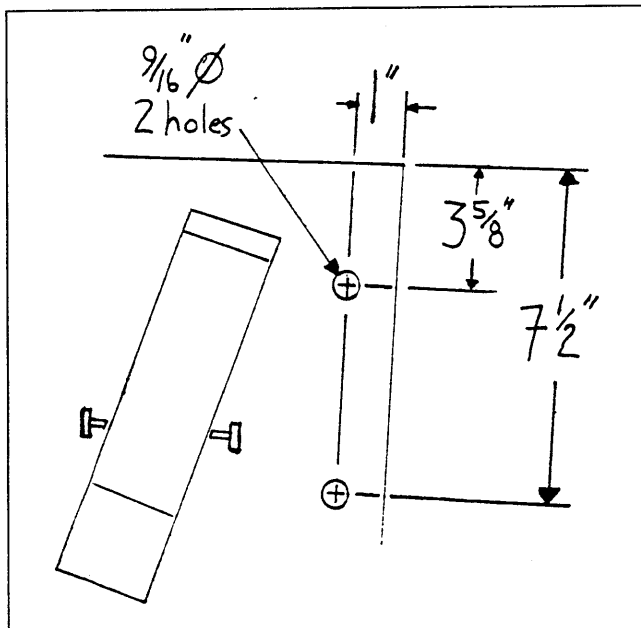

Figure 6

14. Take the left front bracket support (6) and position it underneath the operator foot platform. Align the top two-hole bolt pattern with the brake pedal bracket holes, and side two-hole bolt pattern with the side platform holes. Loosely bolt the support, through the bracket, to the platform using the 1/2"x1 1/2" hex bolts, hex nuts, and lockwashers supplied. Ensure the bolt heads are

to the top (see Figure 7, right side shown).

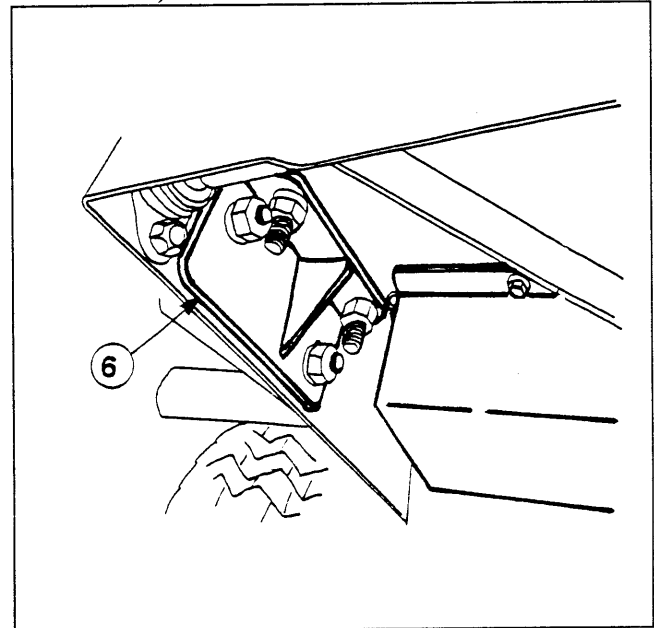

Figure 7

15. Take the left front bracket (7) and position it against the outside of the two-hole bolt pattern in the operator foot platform side, with the cab mounting plate to the front and outside. Loosely bolt the bracket, through the platform, to the support using the 1/2"x1 1/2" hex bolts, hex nuts, and lockwashers (see Figure 8).

16. Repeat steps 14, 15 for the right front bracket.

17. **NOW YOU ARE READY TO MOUNT THE CAB.** Place one rubber mount on each cab mounting plate of the front and rear brackets. Lift the cab, using the lift bolts located near the roof, directly above the unit. Slowly, lower the cab until the cab mounts rest solidly on the

NOTE:

All references to left and right are taken from the operator's point of view when he/she is sitting in the seat.

951D Ransomes ROPS Mounting Instructions

rubber mounts. Bolt the cab snugly to the front and rear brackets as shown in Figure 9.

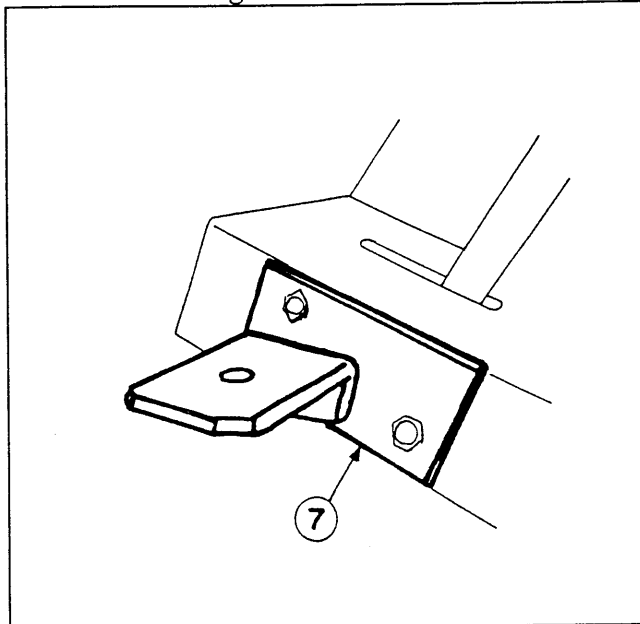

Figure 8

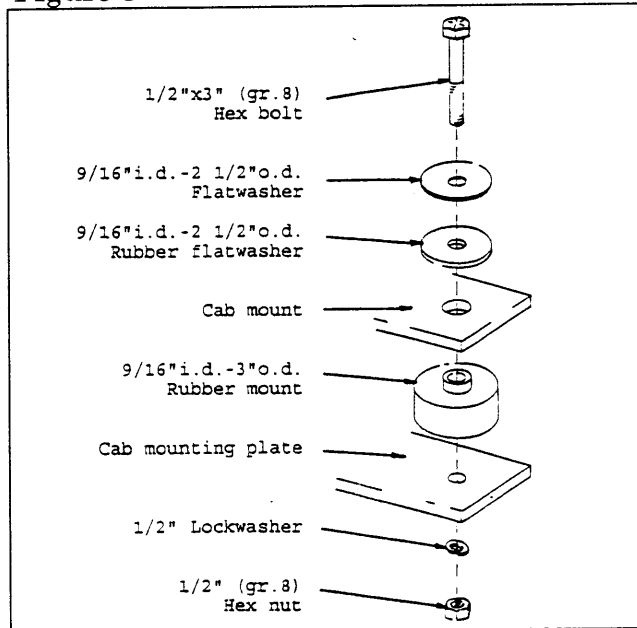

Figure 9

18. Tighten all front and rear bracket bolts.

19. Locate the seat belt tab welded to

the left, rear cab frame. Take one of the seat belt (8) anchors and position it against the inside of the support. Bolt the anchor to the support using the seat belt hardware provided (see Figure 10).

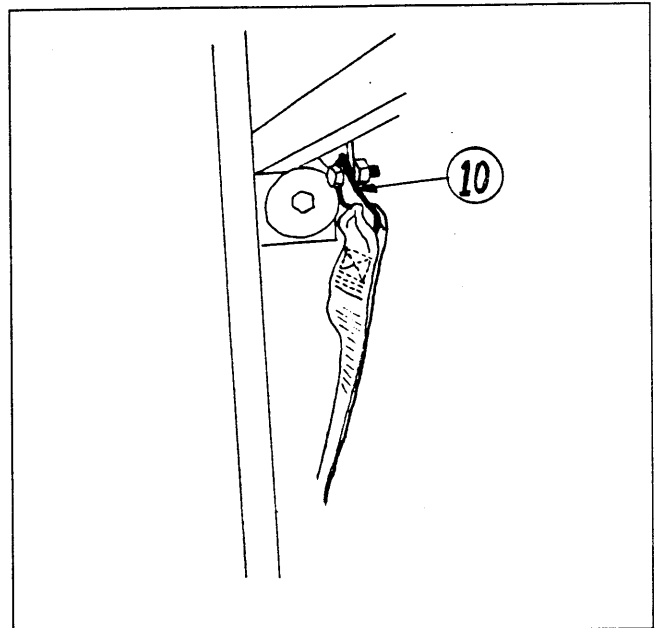

Figure 10

20. Repeat step 19 for the right side.

NOTE:

All references to left and right are taken from the operator's point of view when he/she is sitting in the seat.