

JODALE-PERRY

MOUNTING INSTRUCTIONS

MODEL: 1160 Massey Ferguson
CODE: JDP compact

INCLUDES:
MOUNTING INSTRUCTIONS
PARTS LIST

JDP
BUILT FOR LIFE

Parts List

- 01 - Left 3-pt. lever shield
- 02 - Right 3-pt. lever shield
- 03 - Front mounting bracket (L & R)
- 04 - Hood shield

Bolt list:

- 32 - 1/4" Self-tap screws
- 4 - 12 x 1.75 x 70mm Bolts, washers
- 2 - 1/2" x 3" Bolts, washers

Miscellaneous:

- 6 - Rubber mounts
- 1 - 20 ft. 180 degree O-rubber

Mounting Instructions

1. Remove the 2-post ROPS, seat, front wheel mud guards, floormat, and front platform supports.
2. Take the front mounting brackets (1) and position them where the front platform supports were. Bolt the brackets snugly to the unit using the same bolts which were removed in step 1. (see diagram #1)
3. Take the left 3-pt. lever shield (2) and position it against the rear shield and lever housing*. Firmly hold the shield against the unit and screw it to the lever housing using the 1/4" self-tap screws provided. (see diagram #2)
4. Take the right 3-pt. lever shield (3) and position it against the rear shield and lever housing. Firmly hold the shield against the unit and screw it to the lever housing using the 1/4" self-tap screws provided. (see diagram #3)
5. Move to the cab. Place 180 degree C-rubber (4) along the bottom edge of the side and rear panels of the cab. Beginning at the bottom, left corner work your way up and back toward the rear mount. Then continue to move across the rear of the cab to the right side. Finally, work your way forward and down to the bottom, right corner. (see diagram #4)
6. ONLY NOW ARE YOU READY TO MOUNT THE CAB. Place the supplied rubber mounts (5) onto the front mounting brackets and outside ROPS mounting holes in the fenders. Lift the cab directly above the unit. Then slowly lower the cab until it rests solidly on the rubber mounts. Remember to watch out for the fuel tank cap, steering wheel, and hood while the cab is being lowered. Bolt the cab snugly to the unit using the 1/2" x 3" bolts in front and 12 x 1.75 x 70mm bolts, washers in the rear. (see diagram #5)
7. Take the hood shield (6) and place 180 degree O-rubber (7) along the entire inside edge. Then position the hood shield around the hood so that a proper seal is maintained. Finally, screw the hood shield to the inside of the cab frame using the 1/4" self-tap screws provided. (see diagram #6)
8. Replace the factory floormat and seat.
9. To ensure maximum protection from both moisture and noise entrance into the cab, apply a silicon bead around the entire cab where it contacts the unit.
10. Connect the electrical equipment to a 12-volt source using the 30 amp. in-line fuse supplied.

*NOTE:

All references to left and right will be taken from the operator's point of view, when he/she is sitting in the seat.

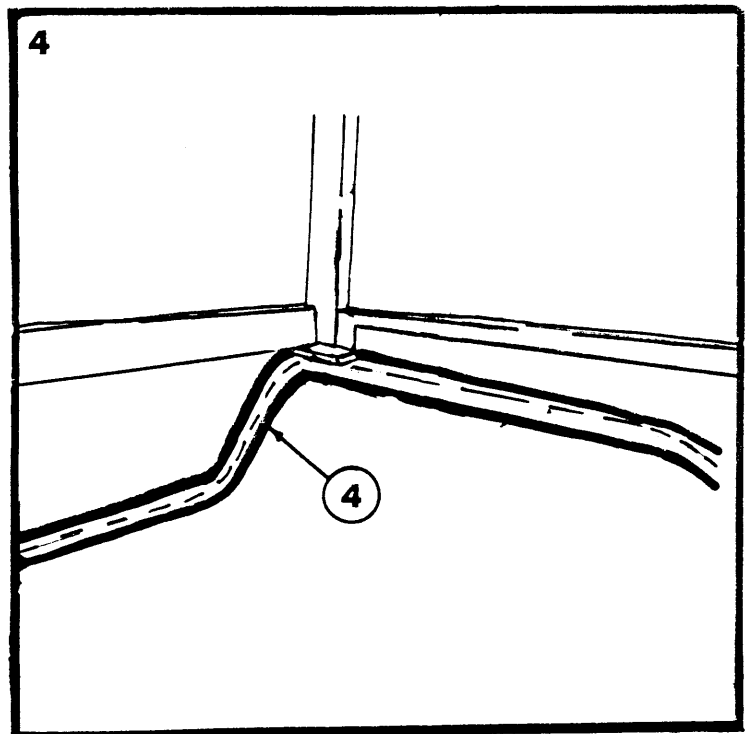
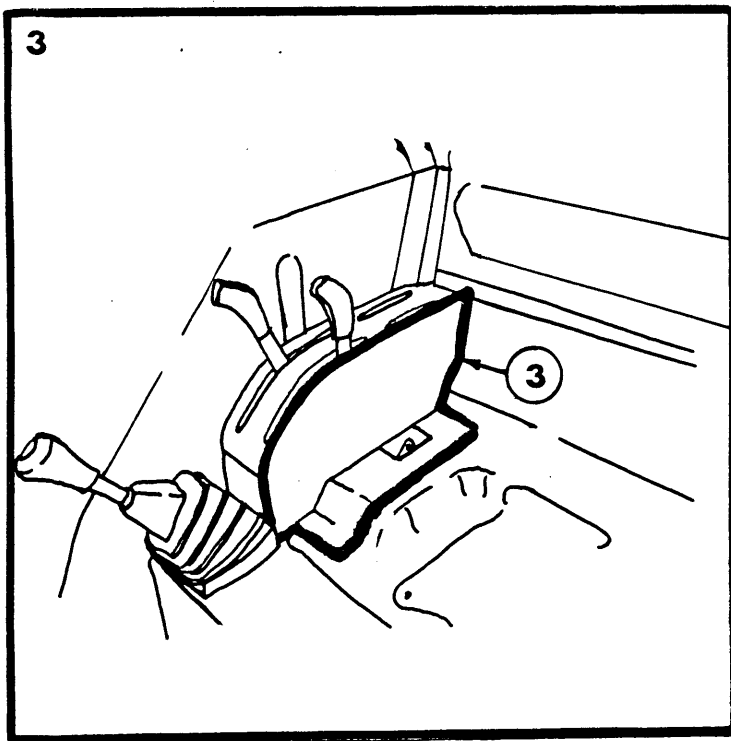
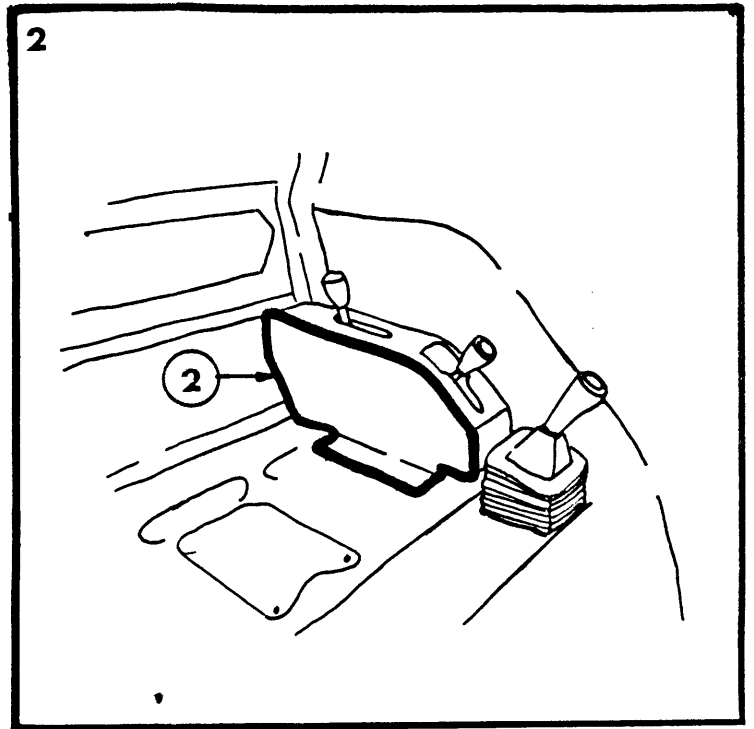
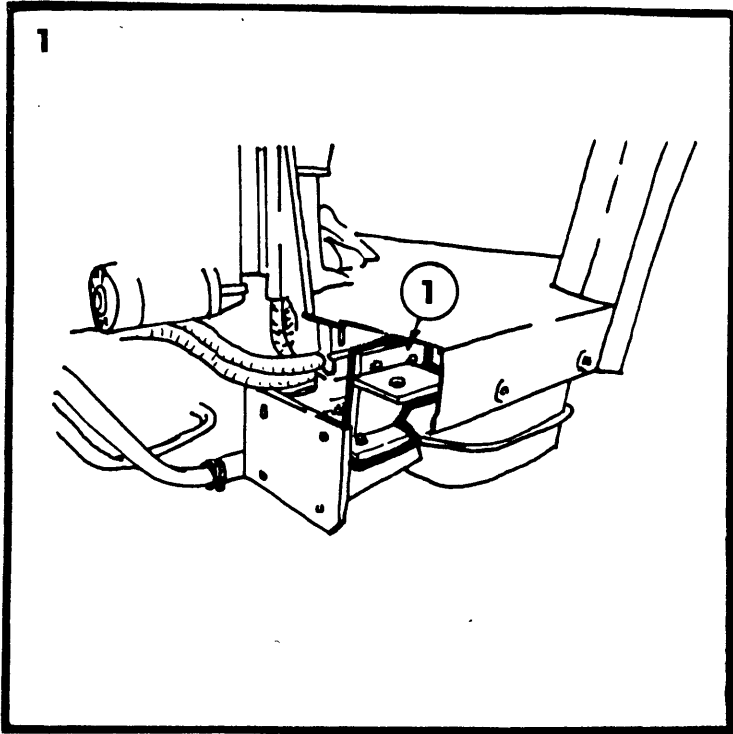

MOUNTING INSTRUCTIONS

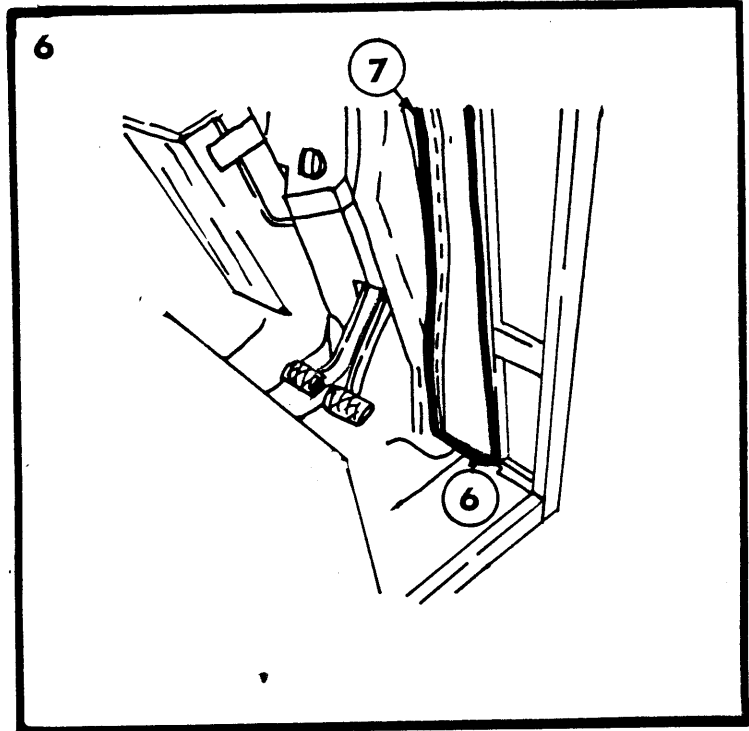
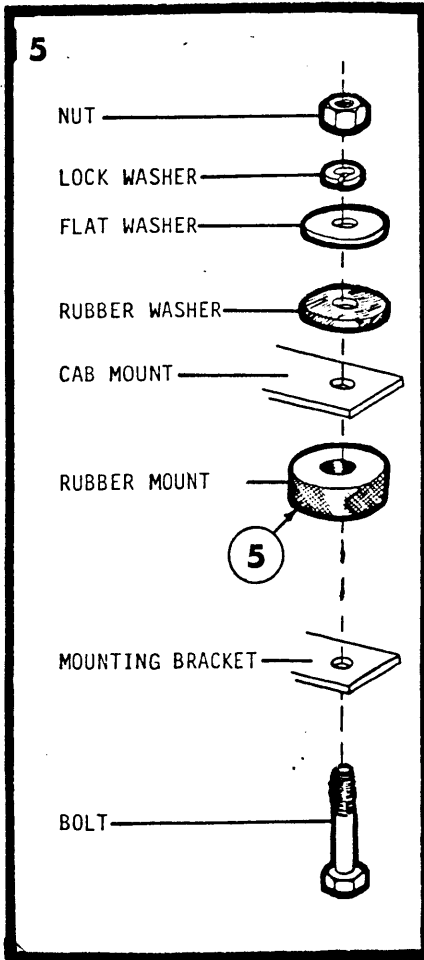

Parts list:

2 - 3/8" NPT - 3/8" Barb - 180 degree Nylon fittings
4 - MH 6 Hose clamps
25 ft - 3/8" dia. heater hose

1. Drain anti-freeze.
2. Locate the pressure plug on the front of the thermostat housing. Remove the plug. Rethread the plug opening with 3/8" NPT.
3. Locate the suction plug on the left side of the water pump. Remove the plug. Rethread the plug opening with 3/8" NPT.
4. Screw in one of the nylon fittings into each of the plug openings. Remember to use a sealant on the fittings to prevent any leaks.
5. Take the heater hose and connect one end to the pressure fitting. Route the hose up the front, right cab post and connect to the water valve.
6. Take the remaining heater hose and connect one end to the suction fitting. Route the hose up the front, left cab post and connect to the heater core.
7. Remember to flush the system to remove any unwanted debris from tapping the plug openings. Flush at least twice.
8. Ensure all connections are tight and fill in anti-freeze.