

# JODALE-PERRY

## MOUNTING INSTRUCTIONS

**MODEL:** MK.V KUBOTA 5450 WITH BF 1100 LOADER  
MK.V KUBOTA 4150 WITH BF 900 LOADER  
**CODE:** KU-15

**INCLUDES:**  
**MOUNTING INSTRUCTIONS**  
**PARTS LIST**

**JDP**  
BUILT FOR LIFE

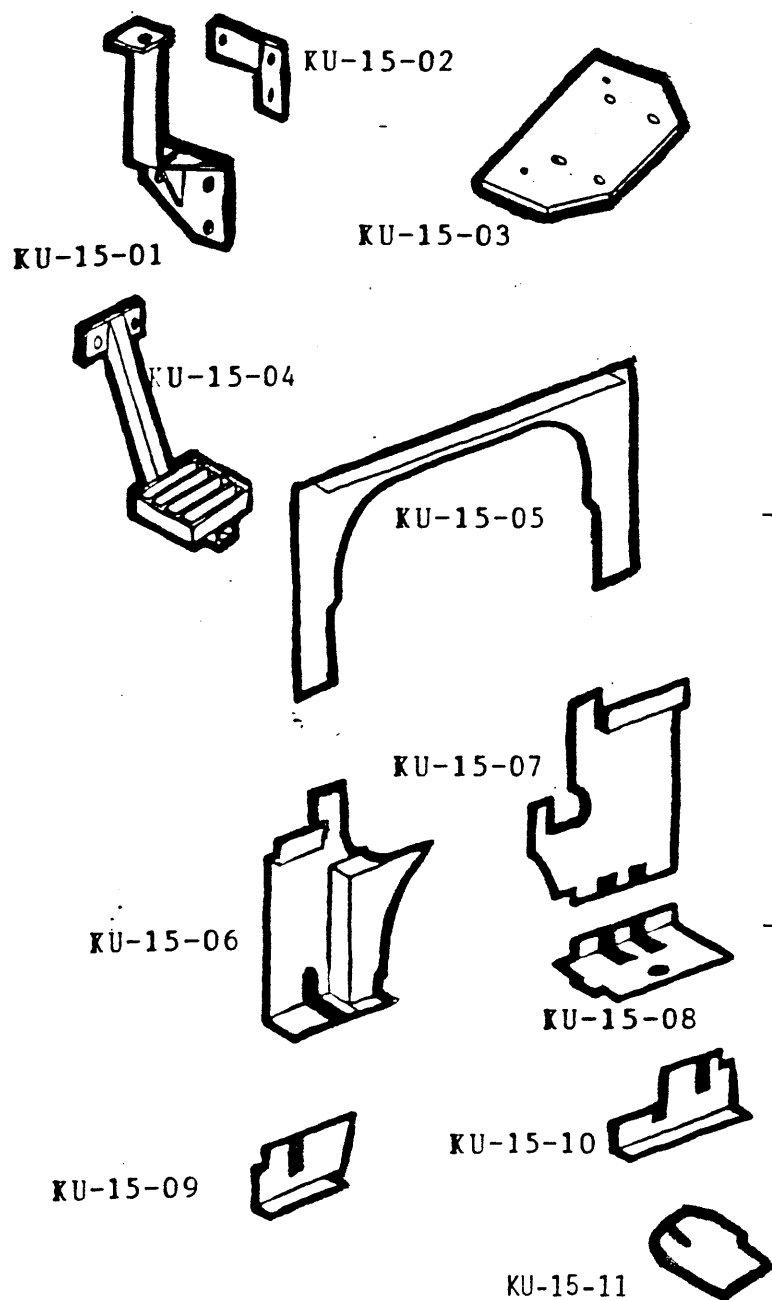

KU-15-01	Front mounting bracket (L & R)
KU-15-02	5/8" Spacer (L & R)
KU-15-03	Rear axle mounting bracket (L&R)
KU-15-04	12" Cab step (L&R)
KU-15-05	Hood shield
KU-15-06	Clutch shield
KU-15-07	Front brake shield
KU-15-08	Brake shield
KU-15-09	Right rear platform extension
KU-15-10	Left rear platform extension
KU-15-11	Throttle platform shield
KU-15-12	Loader control box

---

Bolt list:

60	Self-tap screws
8	1/4" x 3/4" Bolts,nuts,washers
3	5/16" Flatwashers
4	3/8" x 1" Bolts,nuts,washers
6	1/2" x 3" Bolts,nuts,washers
4	3/8" x 3/4" <i>WHITZ BOLTS</i>

---

Miscellaneous:

6	Rubber mounts
96"	180 degree O-rubber
29"	1/4" x 3/4" NDAX
2	18" x 38" Floormat
1	29" x 55" Upholstery

---

FOR TRACTORS WITH BF 900 & BF1100 LOADERS

---

KU-15-12

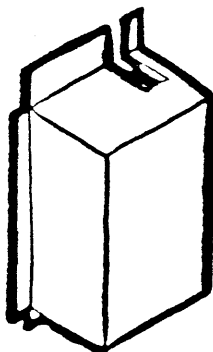

1. Remove the rollbar, fenders, seat, and top rear shield on the gas tank from tractor.
2. Cut the vinyl to fit over the rear seat shield, making the necessary openings for all controls and the seat. Once the vinyl is cut to shape, glue it to the rear seat shield. Also, screw the fenders to the cab before mounting the cab.
3. Loosely bolt the left and right front mounting brackets (1) to the tractor. REMEMBER to use the 5/8" spacer between the bracket and the tractor mount when no loader is being used. (see diagram #1)
4. Bolt the left and right rear axle mounting brackets (2) to the tractor, using the innermost slots of the tractor axle. (see diagram #2)
5. Lift the cab and position over the tractor until the cab mounts and directly over the mounting brackets. Lower the cab until the cab mounts are approximately 4" over the mounting brackets. Carefully, place the rubber mounts (3) onto the front and rear mounting brackets. Finally, bolt down the cab as shown in diagram #3.
6. Tighten the front mounting brackets against the tractor body.
7. Place hood rubber (4) onto the hood shield (5), the clutch shield (6), the front brake shield (7), the brake shield (8), and the throttle platform shield (10) where the shields make contact with the tractor hood or housing. (see diagram #4)
8. Bolt the rear shield to the gastank using the same holes which held on the factory shield on top of the gas tank.
9. Position and screw in the left and right rear platform extensions (11,12). (see diagram #5)
10. Position the clutch shield (6) and front brake shield (7) and screw them into place. (see diagram #4)
11. Position the brake shield (8) and screw it into place. (see diagram #4)
12. Slide on the hood shield (5) and screw it to the outside of the cab. (see diagram #4)
13. If the tractor is equipped with a loader, slide the loader control box (9) over the loader controls and screw the box into place.
14. Replace the seat.
15. Position and bolt the cab step supplied to the cab frame below the door.
16. Cut the floormats to fit snugly around all controls and openings.
17. Connect the electrical equipment to a 12 volt source using the supplied 30 Amp. inline fuse.

PLEASE NOTE:

There is no warranty on glass. We are not responsible for injury to anyone by our products or any part thereof.

